

## Analysis and Optimization of Fiber Reinforced Composite Structures

### **Composite Revolution**

Swapping out steel structures with engineered composite structures is nothing new or even novel. What is a bit unique is the maturity of the process where the complete engineering cycle from objective to engineering drawing package can be delivered in three weeks. At Predictive Engineering, we specialize in quick turnarounds of demanding engineering projects where accuracy and cost effectiveness are crucial to our client's success. In this case, an existing steel structure that is used to create a fish passageway at a large hydroelectric dam had to be replaced with a non-magnetic structure to allow the use of radio-frequency fish monitoring electronics in time for the spring downstream salmon migration. To meet this schedule, the analysis, optimization and the design package was completed in less than six weeks and our client was able to get the new composite structure installed in time that nary a salmon was missed.

**Model Details:** The main body of the flow spreader consists of a high density foam core coated with an FRP skin. Although we could have modeled this as an idealized NX Nastran plate element, due to connectivity requirements to the rest of the structure, the foam core was modeled using 8-node bricks and then surfaced with plate elements to model the fiberglass sheet skins. This technique provided high-quality results for the composite structure and allowed efficient bolted joint modeling. The FRP structure was bolted onto a steel frame structure modeled with plate elements. Contact between parts of the structure were enforced using the linear contact feature within NX Nastran.

**Analysis Tools:** The model was constructed in Femap v10.1.1 and analyzed with NX Nastran 7.0. Analysis times for this model were on the order of minutes.

**Note:** Predictive Engineering has experience in the modeling of carbon composite structures used in military and commercial applications that included: drop testing; Interlaminar CTE stresses, standard stress analysis, and curing analysis.

# Rocky Reach Dam

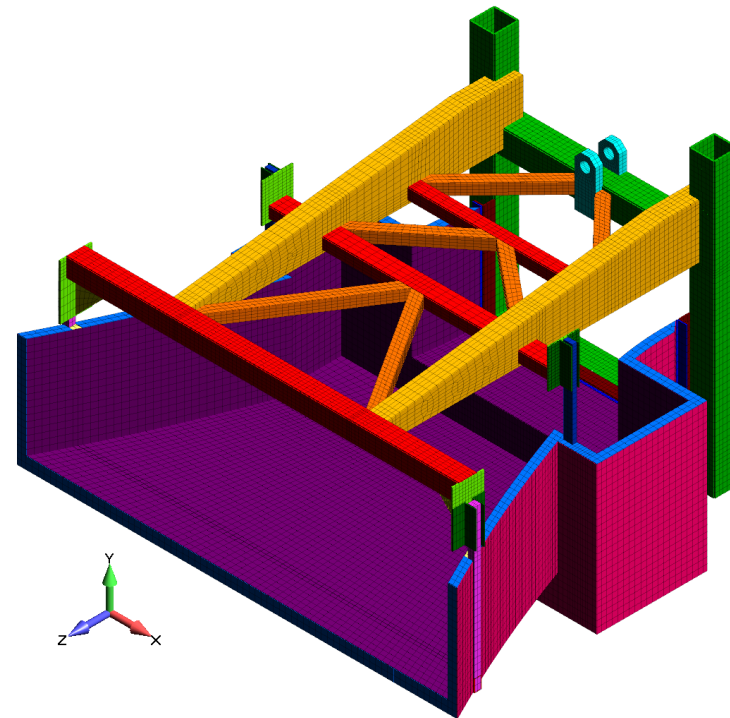

For the operators of the large hydroelectric dams on the Columbia River, enhancement of salmon runs is a key priority. This project replaced existing steel fish passageways with high-strength composite structure that would allow the use of sophisticated fish tracking magnetic field sensors.

# Analysis and Optimization of Fiber Reinforced Composite Structures

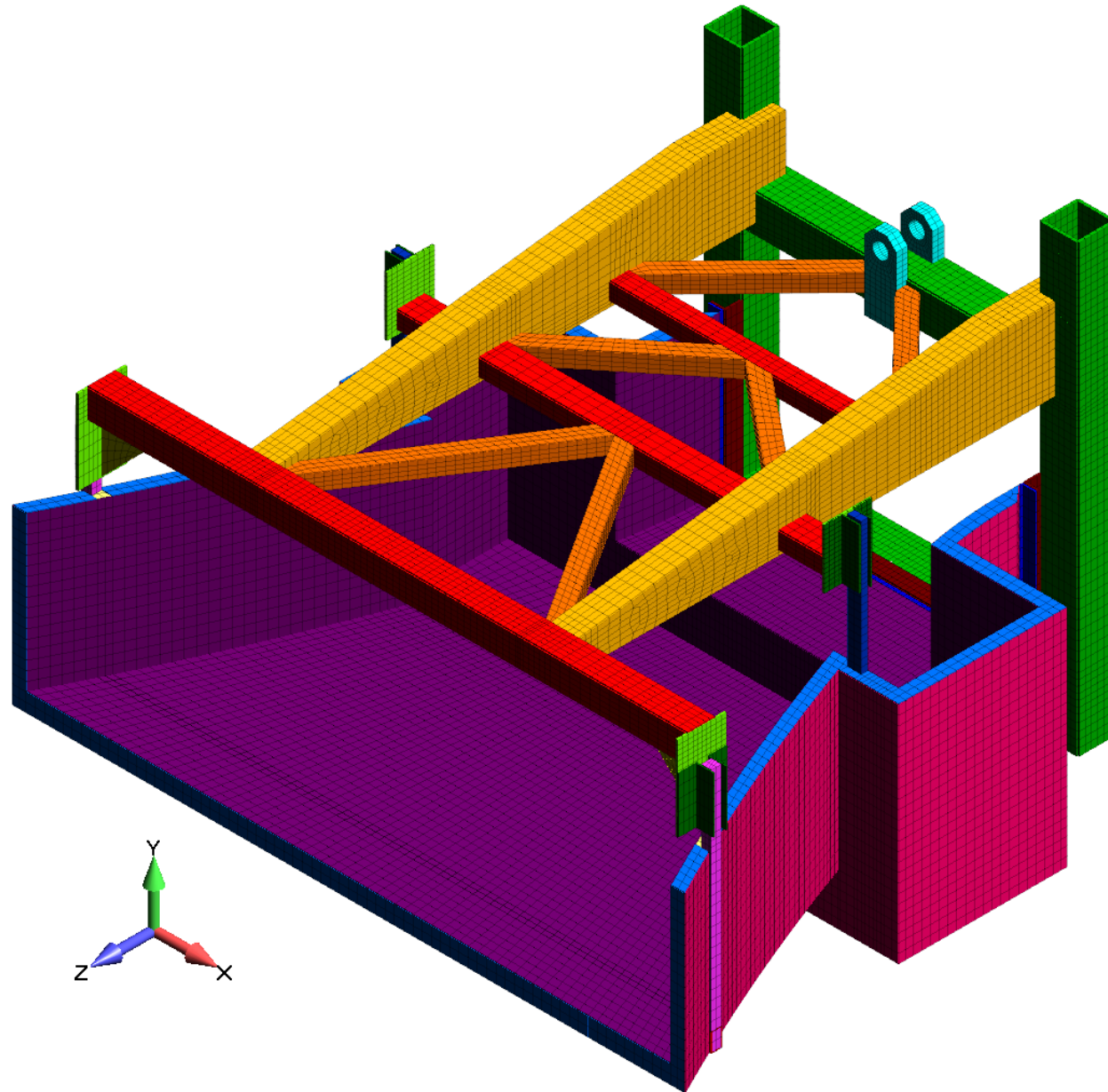

## Analysis and Optimization of Fiber Reinforced Composite Structures

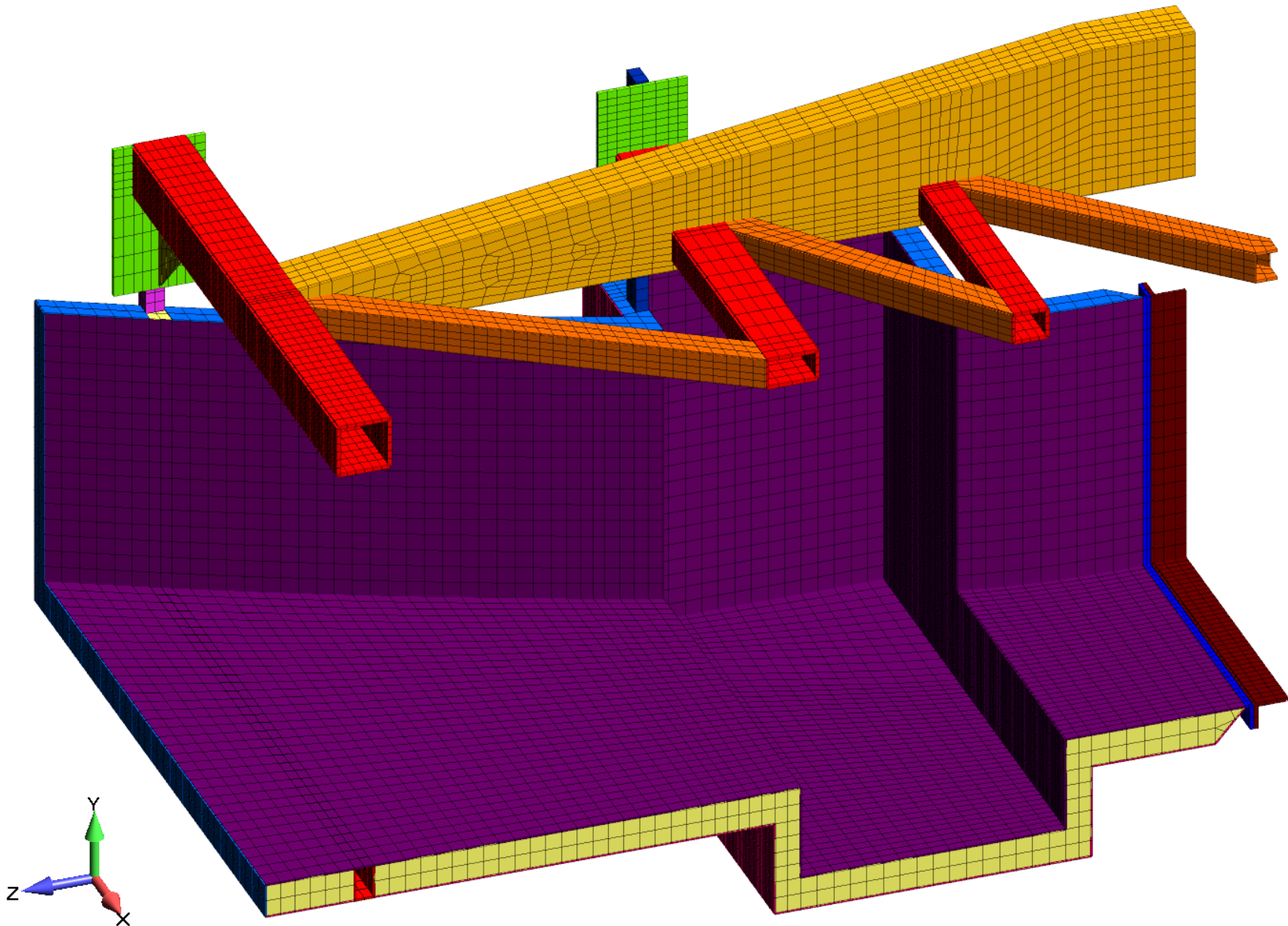

# Analysis and Optimization of Fiber Reinforced Composite Structures

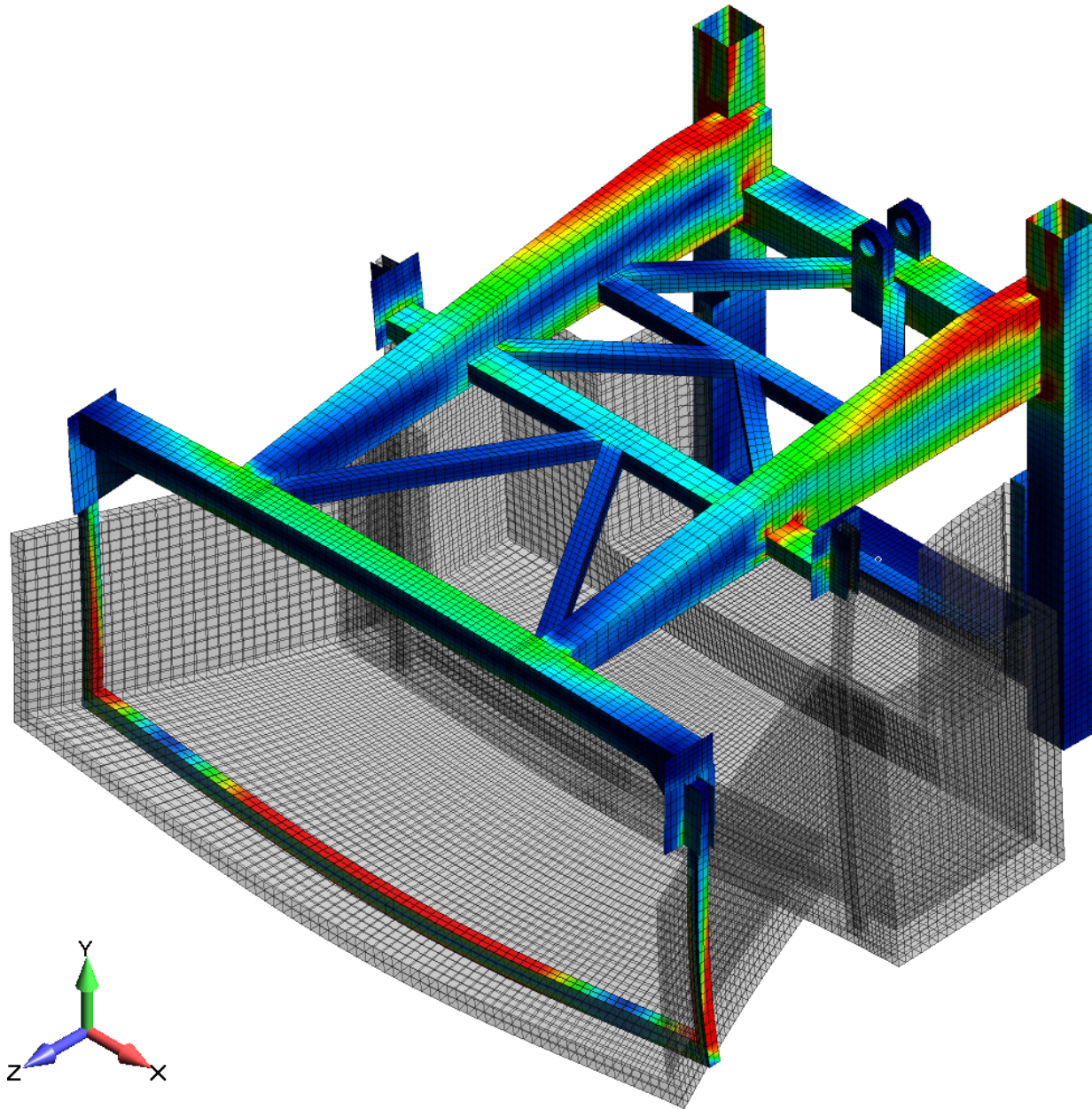

Stress results contoured over the steel components of the structure.

# Analysis and Optimization of Fiber Reinforced Composite Structures

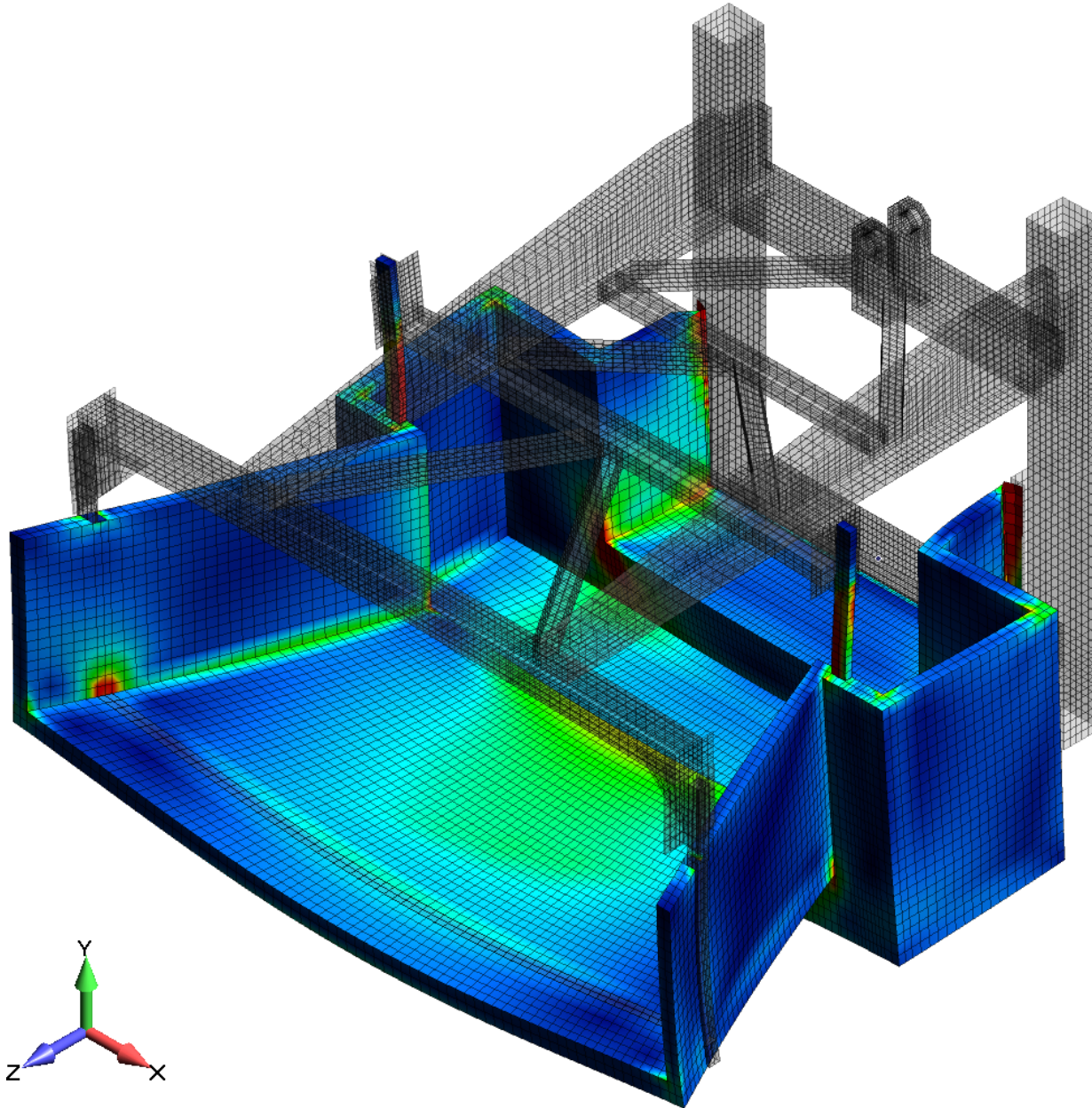

## Analysis and Optimization of Fiber Reinforced Composite Structures

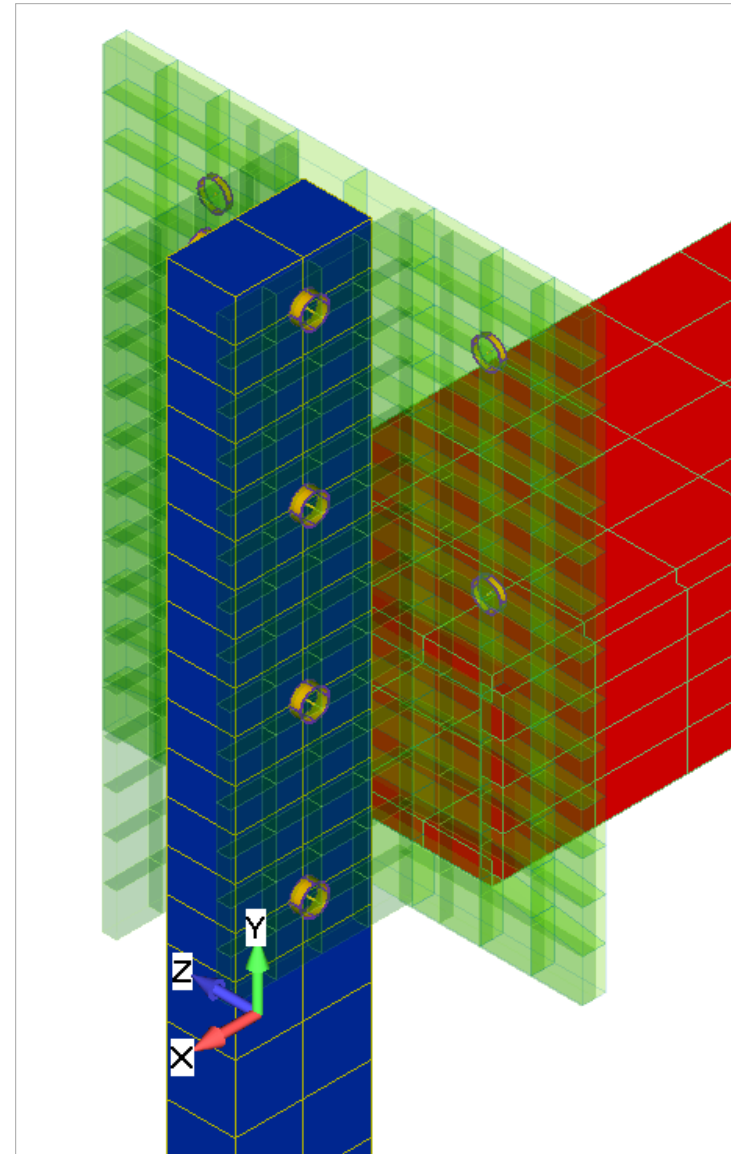
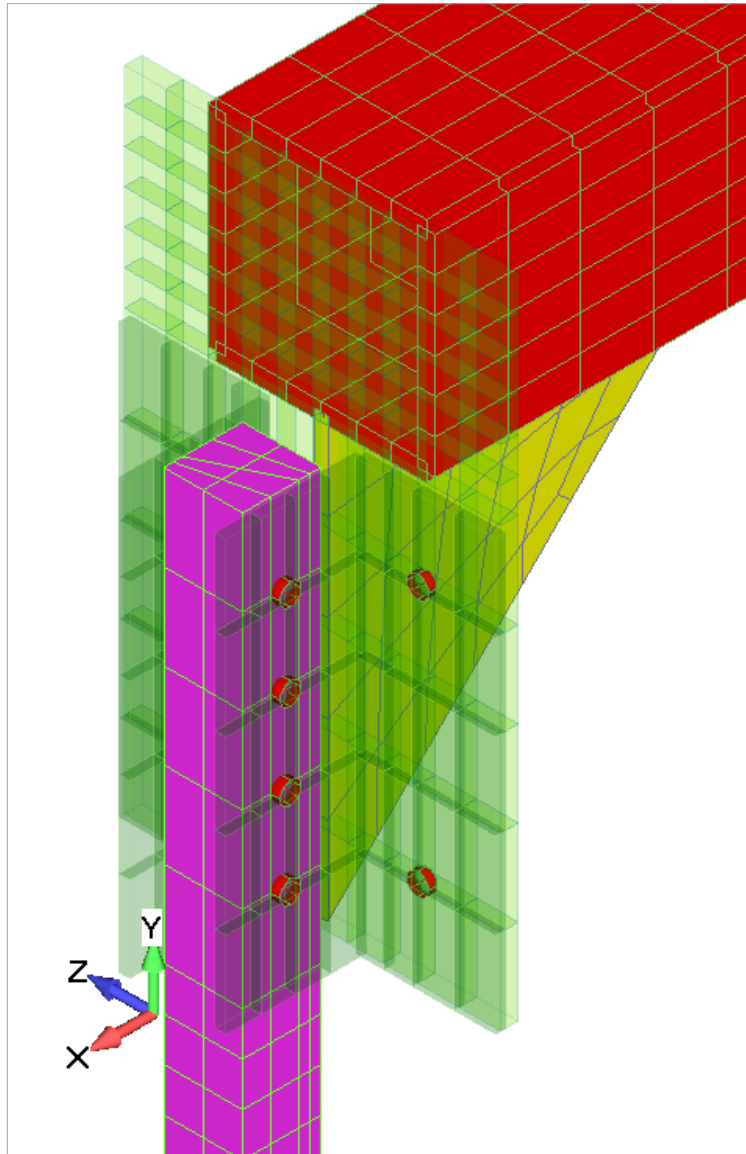

## Analysis and Optimization of Fiber Reinforced Composite Structures

