

FINITE ELEMENT ANALYSIS



Predictive Engineering

Vibration Analysis of Engineered Structures and Systems





Vibration Analysis of Engineered Structures and Systems

Numerical vibration analysis is one of the core skill sets at Predictive Engineering. Our work has been tested, shaker-tabled and in-the-field benchmarked with tightly correlated outcomes on every model. An industry axiom for vibration work is that a numerical model is normally no better than within 20% of reality. Over the years, our models have consistently been within 10% of experimental measurements and our mode is typically 5%. Our clients have come to expect such agreement and they understand that it is due to our hard-won experience in the idealization of engineered systems into high-fidelity finite element analysis models.

Summaries are presented to show a portion of the work that we have done over the years in the fields vibratory conveyors, automotive, scientific, manufacturing and aviation. Many other examples are available for discussion but these projects provide distinctive insights into how we build and benchmark our analysis work.



Normal modes, frequency analysis and transient dynamic analysis were applied to the design of novel vibrating conveyor systems. Predictive Engineering was able to provide “first time” correlation with experimental results. Analysis work laid the foundation for wide-spread adoption of FEA based vibration simulation at Key Technology. This partnership continues today with follow-on coaching and training.

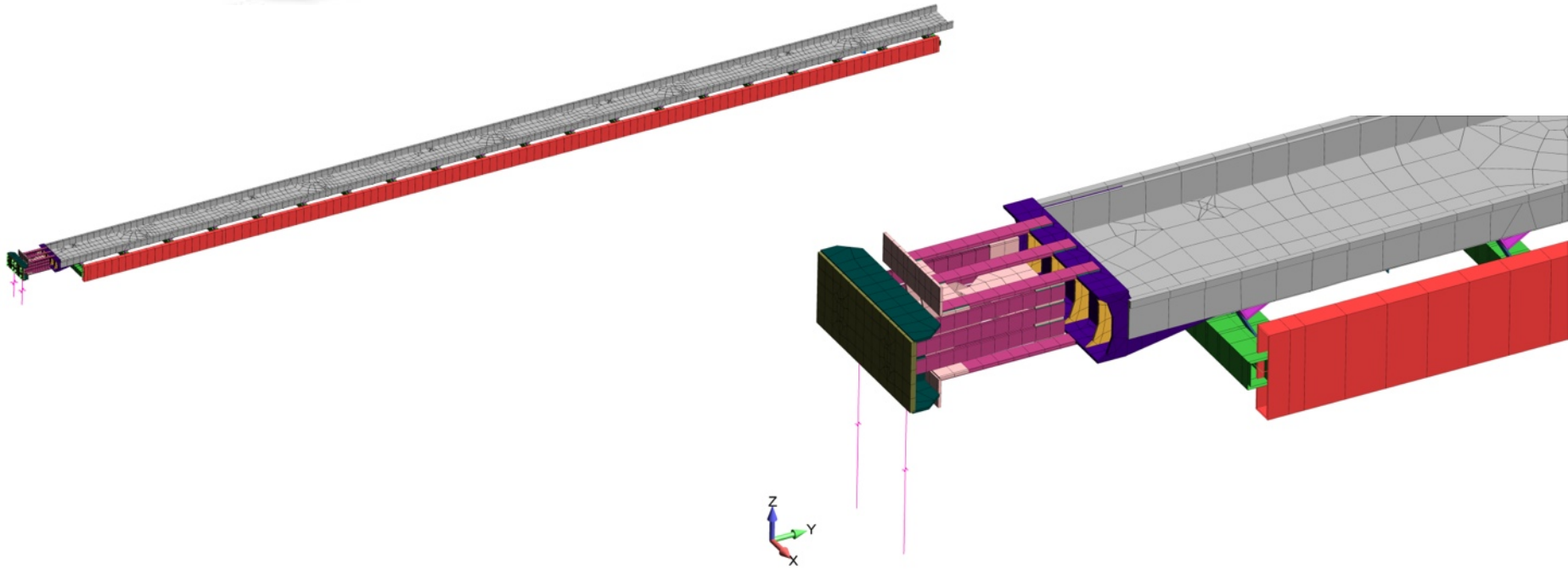

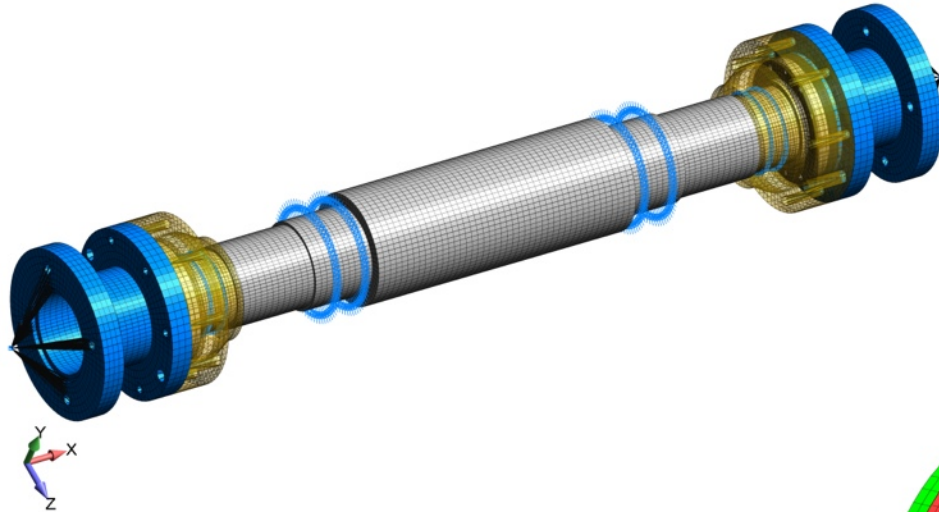

Normal modes analysis was performed on a series of driveshaft and cold-spinning motor testers. Each model was blind benchmarked against experimental data and found to be within 4 to 8% of experimental data. Analysis work was used to document new designs to up-stream clients and to obtain approval for large-scale manufacturing implementation.

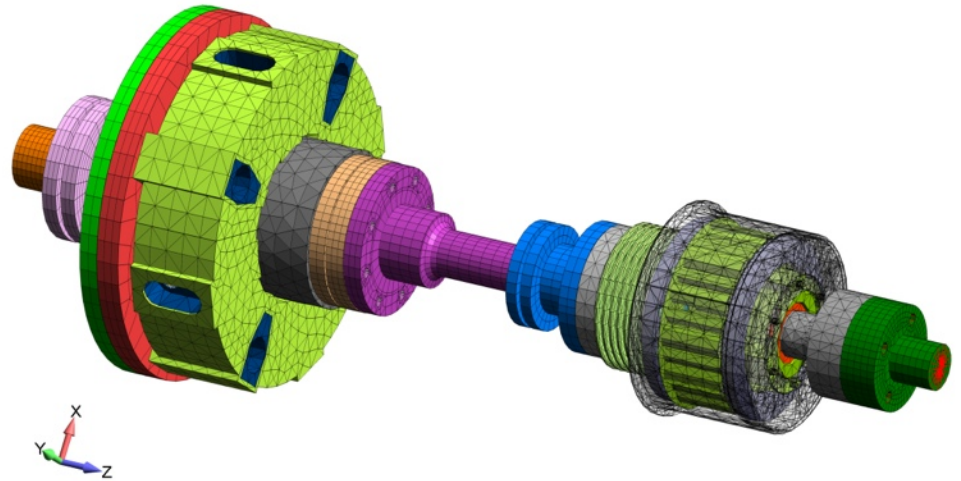

Scientific Components and Instruments

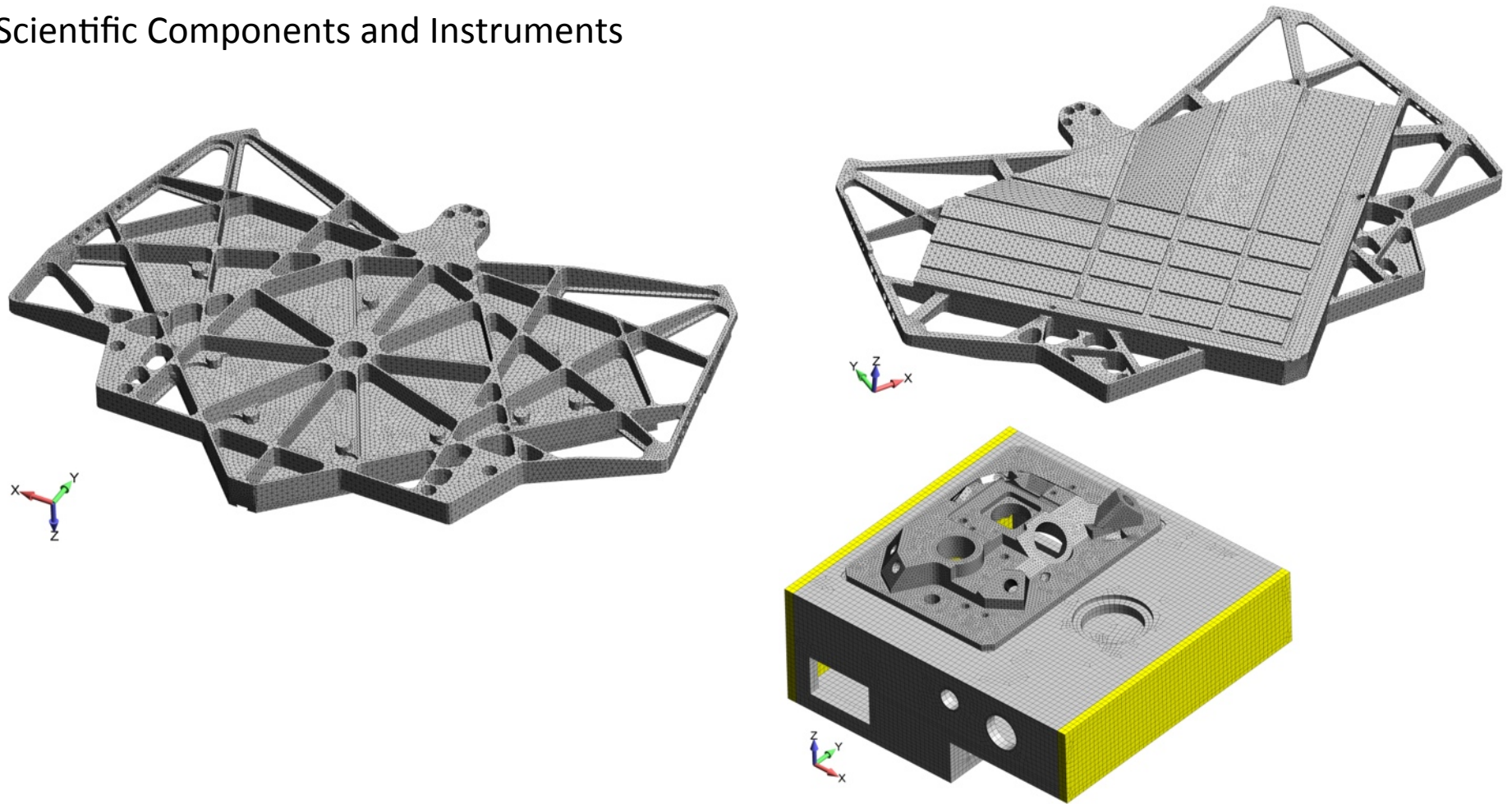

Although the normal modes analysis of single component structures or glued-together assemblies is routine, these models required exacting precision due to their high-technology requirement as part of an electron microscope. Vibration work was validated against experimental measurements and found to be within 3 to 5%. Analysis work allowed the client to proceed to manufacturing with no further testing.



Assembly-Line Manufacturing Equipment

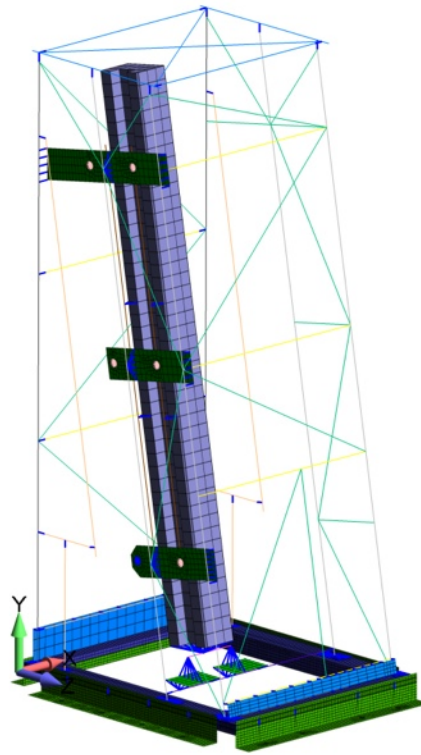
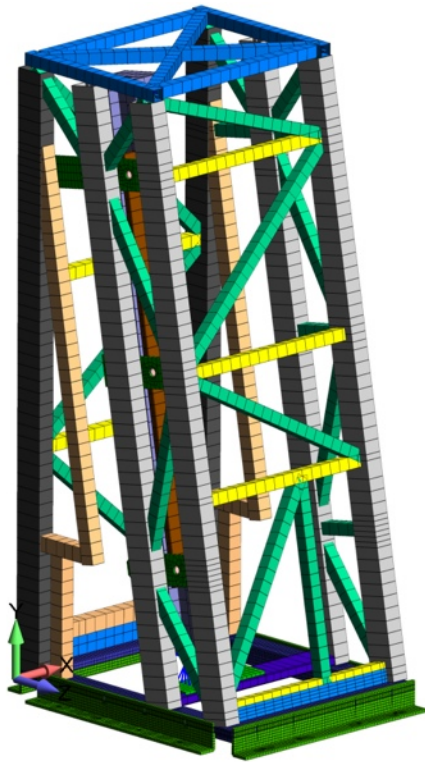

Assembly line equipment for the optical inspection of LED panels. The frame structures held the panels while they were optically scanned. The camera movement created random vibrations within the frame that affected the image quality. Normal modes and frequency analysis work led to improved designs that allowed faster line speed while improving image quality.

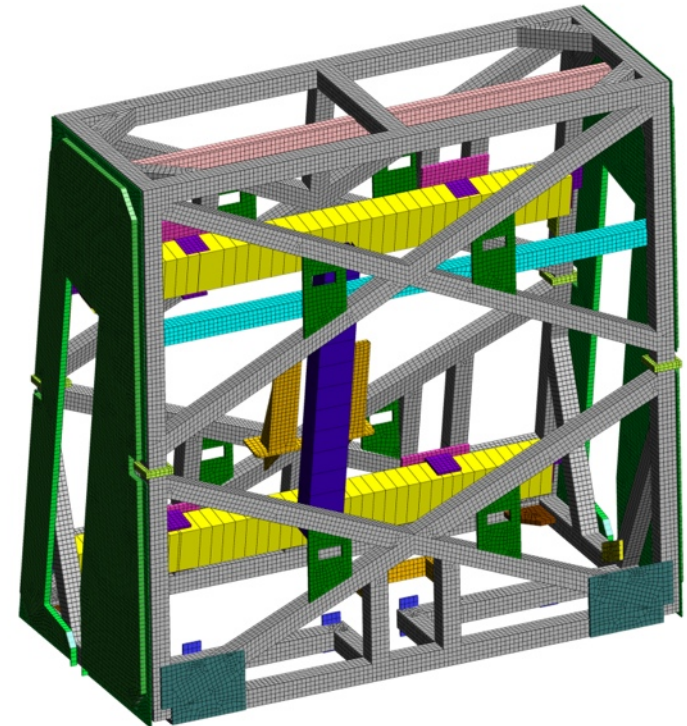

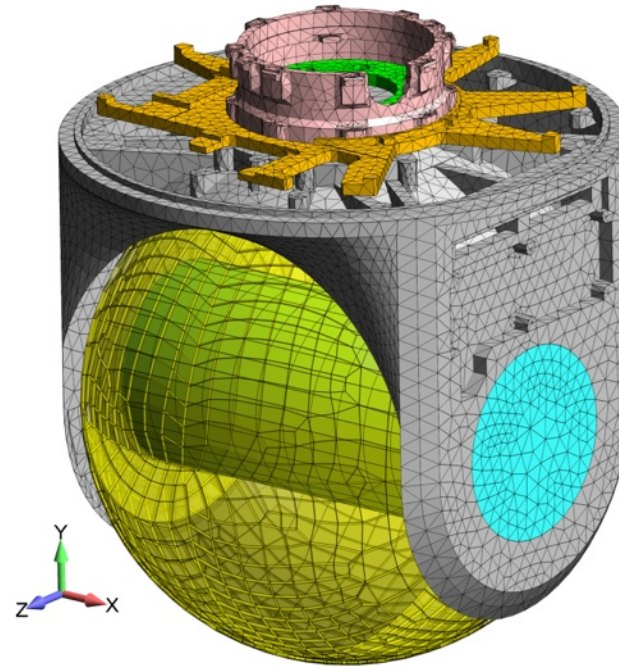

Aviation hardware presents special challenges due to an exacting and demanding service environment. Normal modes and frequency sweep analysis work has been validated against shaker table work on several occasions. Project work continues to this day with follow-on work with thermal and drop-testing analyses.

